Emoto: From Phone to Emotive Robotic AI Sidekick

Gautam Bose*

Carnegie Mellon University
Pittsburgh, PA 15217, USA
gautam.bos3@gmail.com

Marisa Lu*

Carnegie Mellon University
Pittsburgh, PA 15217, USA
contactmarisalu@gmail.com

Lucas Ochoa*

Carnegie Mellon University
Pittsburgh, PA 15217, USA
lucasochoa96@gmail.com

Dan Lockton

Carnegie Mellon University
Pittsburgh, PA 15217, USA
danlockton@cmu.edu

*The 3 above authors contributed equally to this work

Permission to make digital or hard copies of part or all of this work for personal or classroom use is granted without fee provided that copies are not made or distributed for profit or commercial advantage and that copies bear this notice and the full citation on the first page. Copyrights for third-party components of this work must be honored. For all other uses, contact the Owner/Author.
TEI '19, March 17-20, 2019, Tempe, AZ, USA
© 2019 Copyright is held by the owner/author(s).
ACM ISBN 978-1-4503-6196-5/19/03.
DOI: <https://doi.org/10.1145/3294109.3301260>

Abstract

In this paper we introduce the concept of Phone as an Emotive AI sidekick through a set of novel interactions wherein a multi-axis actuated robotic charging stand we made acts as a 'body' for the AI on our phones. The novel interactions begin with how the robotic platform embodies and thus communicates our devices' understanding of the world, continues with the affordance for more varied expressive output, and works towards extending current phone functionality to be far-field, context-driven interactions.

Author Keywords

Embodied interaction; tangible; robotics; emotive; multimodal communication; intelligent personal assistant;

CSS Concepts

- Human-centered computing~Smartphones
- Human-centered computing~Personal digital assistants
- Hardware~Sensor devices and platforms

Introduction

Personal robotics has long held our collective imaginations, from research labs to pop culture fads and science fiction dreams. However, much of the high impact innovation we see in robotics has been industrial or otherwise in early research phases with limited trickle down towards consumer products [18]. More recently, the explosion of conversational home

Industry



Figure 1: Anki's new Vector exploring a desk. Its charging home base is behind it on the right



Figure 2: We prototyped animations with paper protractors stuck into the joints of a miniature 3D print we made of Baidu's AI robot by Teenage Engineering

assistants, everything from Google Home Minis to emotive desktop robots by Anki [5] (Figure 1) has given rise to new practices and expectations for the kinds of devices we find acceptable in our homes and what their capabilities can or should be. Alongside this, the growing scrutiny of our relationships with devices and their content has been more openly addressed. Shareholders wrote to Apple requesting "more choices and tools" [10] to help set limits on children's phone time. But is improving how we relate to phones a matter of control? When Facebook announces an overhaul of algorithms for Newsfeed to enable more "meaningful interactions" [3], what does that entail? It didn't change how we engage with devices, though it's clear we are affected by how we use our technology; Amazon released a "child-friendly" Echo in response to concerns about smart speakers effecting children's burgeoning manners. Research corroborates that it is not merely the content of what we say or do, but how we, and our technology, communicate that greatly affects collaboration [1]. The launch of the Center for Humane Technology, a coalition of former tech employees alarmed about the impact of the technologies they helped create, is yet another example that our relationship with smart devices is on many peoples' minds. An increasing number are concluding that we don't necessarily like how smartphones have changed us. There will be no abrupt, sustained cessation of smartphone use, so perhaps it's time to reframe the relationship. In order to change the current paradigm, it is necessary to introduce a new, but still familiar metaphor as people tend to engage with concepts they find familiar [4].

Related Work

Our thinking drew experience from MIT Media Lab's Social Robotics group with their explorations on the effects of different modes of nonverbal and verbal communication, to pop culture examples inspired by HRI research on designing robot behavior based off fictional sidekick characters [10]. By learning from design principles of fictional sidekick characters, we shift the emotional frame of engagement with robots and phones. Previous studies on reciprocity between people and robots have already shown that perception of peer-like social robots as curious, in turn promotes curiosity in children via co-play [12]. Testing through experiential storytelling as research probes allows us to better understand what a sidekick robotic phone "must do, should do, and could do" [11]. This sort of inquiry through making we did draws from Dunne and Raby's approach where design is a tool to "pose 'what if' questions intended to open debate and discussion about the kind of future people want (and do not want)" [7] The related approach of design fiction, increasingly prevalent in HCI [8], is appropriate here, in enabling exploration of novel interactions even where its technology is not yet fully developed.

A specific industry inspiration for our first probe was Baidu's robotic arm (Figure 2) for their AI. It's an exciting exploration in expressive motion that could be pushed further towards ecosystem integration. Other consumer products that move towards framing intelligent personal assistants as emotive sidekicks have also been developed [6], bringing relatively cheap, sophisticated robotics into the personal space.

Prototype Details



Figure 3: Phone in 'Emoto' mode



Figure 4: Robotic base with phone magnetically docked and charging

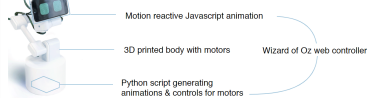

Figure 5: A breakdown of the components of Emoto

Goals

Our work explores the vision of an artificially intelligent sidekick for the home through a novel robotic prototyping platform. The speculative design shows a personal robotic device that modularly integrates with a smartphone that displays "eyes". The robotic base and arm work together to display expressive movement in response to direct or contextual input. Our goals are twofold: first to introduce novel interaction design around how we understand and associate with AI's, the second is to cumulate those interactions towards reframing the relationship with phones beyond the touchscreen paradigm that's fairly isolated from the physical environment.

Emoto's Attributes

Emoto's physical attributes can be broken down into two key components: first is the five axis robotic arm, and the second is an AI driven phone that docks and charges on the robotic base.

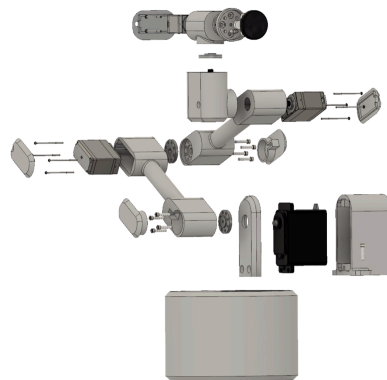

Figure 6: To facilitate low cost prototyping we designed and 3D printed all custom parts and used hobby servo motors.

Robot Platform

There are two motivations for implementing Emoto's five axis robotic arm. We wanted a physical platform to embody different interactions and create a semblance of sentience. It doubles as a specific and purposeful place for your phone to be at home rather than attached to your person. Placemaking for the phone shifts explorations more towards far-field interactions than touch-screen ones.

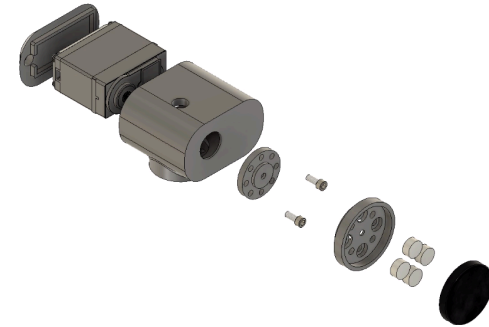

Figure 7: To allow easy attachment of phone to the emoto body we retrofitted a car phone holder magnet directly to the servo.

AI Driven Phone

The other key element is the phone that rotates itself into the face of the Emoto character upon magnetically docking to the robot base. The transformation is an important one because the user sees their AI/phone 'come to life', and become 'aware' of its environment.

In a sense, this moment is also where the user's phone stops being controlled imperatively by the user but instead becomes 'AI driven' and by extension, context driven. We think of this as a mode where the Emoto character or personality can serve as an intermediary

Phone to Sidekick

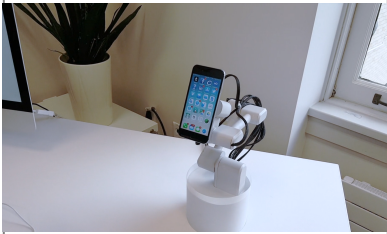

Figure 8: Docking your phone to charge



Figure 9: Device begins to transition.



Figure 10: The device comes back to life as the character of Emoto.

layer between the user and the functionality in their phone — a layer that is able to have more embodied and emotive qualities from the increased input (microphone and camera visuals) which enhance communication with the user.

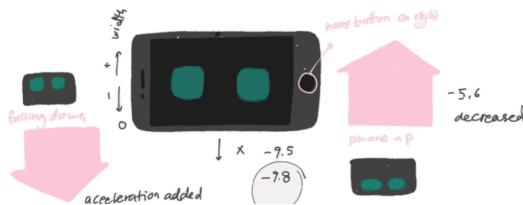

Figure 11: The physics of the spring system behind the eye shape is tied to the accelerometer on device. The eyes flicker, turning to look at stray noises in the room.

We took steps to avoid known behavioral biases in the visual form of the eyes; it has been shown that humans treat robots differently depending on how they perceive the robot's gender [14], social categorization [15], personality [16], and intelligence [13]. We take this into account by using a fairly soft geometric form, in a light green-blue with ray traces generally reminiscent of science fiction robot sidekicks. It is not immediately clear if the character has a gender. Its novelty and generalized form means we start with fewer associations that may imply, or set expectations for intelligence, personality, and by extension what its abilities should or could be. With solely conversational UI based AI's like commercial Siri, the adult voice has associated expectations for a higher level of intelligence or competence than the current nascent technology can yield. The proportionally large eyes paired with the slender form factor and implied curious behavior is

more likely to be perceived and treated as a child than an adult.

Emoto's Interactions

We prototyped a set of interactions and scenarios that attempted to create the illusion of a character users would be able to engage with. By considering the full journey from placement of phone onto robotic base, we show how our system can exist harmoniously with already existing practices.

Phone to Sidekick Transition

We wanted to create a memorable first impression of Emoto so making sure that there was a seamless transition from smartphone to AI Sidekick was of upmost importance. We deliberately have Emoto change from phone home screen to its characteristic eyes while the screen is facing down and away from the user. Emoto shakes his head to imply waking up from a deep sleep.

Contextual Awareness

After the transition from phone to AI sidekick, Emoto needs to gather some understanding of the world around it. Emoto acknowledges its environment, pausing at objects and people of interest. This type of "curiosity" is akin to Anki's Vector bot. [5]

Display of Awareness

While gathering adequate information by looking around curiously Emoto makes subtle changes in posture, using body language to express familiarity through 'upbeat' posture or lack of understanding towards a new setting or people with timid curiosity. It's ability to display understanding also gives it a unique way to take in voice commands. Users don't wait for a light to turn or a beep to sound to indicate

receptiveness because Emoto can show active listening. Displaying contextual awareness can also be extended towards emotional reciprocity. It has been established that a robot's ability to express and recognize people's emotional states through nonverbal channels is at the core of artificial social intelligence [17]. The specifics applied to how we should design emotional displays during active assistant use is something we hope to delve more rigorously into.

Extends Current SmartHome abilities

There is opportunity for an Emoto-like system of integrated robot, speaker and phone to be the next evolution of SmartHome Assistants like Google Home. Phones have more personally customizable settings, and 'functionality' because users choose to download apps as needed.

Ambient Behavior

The aforementioned micro-interactions more often than not have been prototyped and staged around user interaction. Feedback during our design process from peers described an agent as feeling more 'alive' if there were independent, unexpected behavior. So, what should Emoto do, when it isn't 'supposed' to be doing any particular tasks? Exploring ambient behaviors raises the question of when they straddle the line of uncomfortable, and invasive.

Preliminary User Probes

We tested our storytelling through the Emoto robot prototype in two ways: first through video posts to get varied online interpretations, and through an in person 'scenario' walkthrough demo at a design exhibition, and secondly through a concept video that we published on

large social media channels. We invited visitors — mainly design and HCI students and faculty — to watch and interact with the Emoto prototype as it ran through its Phone-to-Sidekick transition, and asked them to think aloud about their reactions and understanding of what was going on.



Figure 9: A walkthrough of Emoto's WOZ routine where the 'facilitator' introduces Emoto to a 'friend', the visitor.

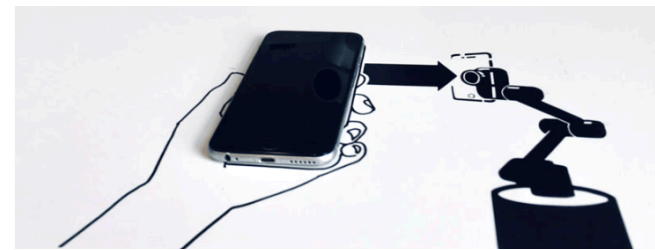

Figure 10: Show time had vinyl graphics on the table as to prompt visitors into the experience.

Of the 37 people who took part, approximately two-thirds appeared to believe the Emoto robot was interacting directly with them. We enabled this through different WOZ controlled behaviors playing out as our

facilitator (someone Emoto was supposed to be 'familiar' with) and the participants 'meet' Emoto.

Comparative Emotional Review

To further supplement our design process after our first public probe, we lived with Anki's Vector home assistant. In reflecting on the emotional experience of having a 'sentient' robot, it was disheartening when the expectations raised by the masterfully implemented animations, did not match the technical reliability. The dissonance is what makes a charming interaction potentially heartbreaking. As we develop farther, and identify other interesting moments of transition and blurring between emotive character and information display, we want to keep in mind what sort of expectations the onscreen visuals and animated motion set. Emoto's emotive qualities should set expectations for its technical implementation in order to maintain consistency.

Conclusion and Future Work

After seeing the responses to the Emoto project we realized there was some value to be distilled from the original concept. The idea of an expressive phone companion seemed like a promising opportunity for exploring the boundaries of human-robot interaction in daily life. Amongst other things it could contribute to expanding far-field interactions with personal mobile devices. We're looking forward to find a way to publish the project as a low cost, open source kit so others can hack, build and modify their own low cost intelligent emotive companion. We are working towards refining several example interactions, like how an Emoto platform might augment video calling and live streaming practices with object-salience driven movement, and gestural mirroring of a caller for a sense of telepresence, to provide as examples in a

library of other micro interactions. Bringing all of the interactions out of a staged, semi-functioning state towards robust implementation. Building a library of such should allow tinkerers to build their own behaviors with the phone-robot platform. Our hope is to inspire a new wave of makers and creators to explore concepts in AI, robotics, and rethink expected smartphone interactions.

Acknowledgments

We would like to thank our peers in our Junior studio for providing invaluable feedback throughout the process. Additionally we would like to thank Josiah Stadelmeier for his expert consultation and assistance in the construction of Emoto's 3D printed parts.

References

1. C. Breazeal, C. D. Kidd, A. L. Thomaz, G. Hoffman, and M. Berlin, "Effects of nonverbal communication on efficiency and robustness in human-robot teamwork," in International IEEE/RSJ Conference on Intelligent Robots and Systems (IROS). IEEE, 2005, pp/708-713
2. Schneekloth, Lynda H., and Robert G. Shibley. Placemaking: The art and practice of building communities. New York: Wiley, 1995.
3. Isaac, Mike. "Facebook Overhauls News Feed to Focus on What Friends and Family Share." Facebook Overhauls News Feed to Focus on What Friends and Family Share, 11 Jan. 2018.
4. M. Luria. 2018. Designing Robot Behavior Based on Fictional Sidekick Characters. Human-Robot Interaction 18, Companion, (2018) 307-308
5. Anki Vector | The Home Robot With Interactive AI Technology | Anki USA. Anki US, www.anki.com/en-us/vector

6. "Jibo Robot - He Can't Wait to Meet You." Jibo, www.jibo.com/
7. Anthony Dunne, and Fiona Raby. 2014. *Speculative Everything: Design, Fiction, and Social Dreaming*. MIT, 2014.
8. Joshua Tanenbaum. "Design Fictional Interactions: Why HCI Should Care about Stories." *ACM Interactions*, Sept. 2014, pp. 22–23.
9. M.Lakoff, G., Johnson, M. 1980. *Metaphors we Live by*. Chicago: University of Chicago Press. ISBN: 978-0-226-46800-6
10. Chris Weller. 2018. "Here's the Evidence Apple Shareholders Used to Show That Smartphones Are Addictive for Kids." *Business Insider*, 11 Jan. 2018, www.businessinsider.com/evidence-apple-shareholders-used-to-show-iphones-are-addictive-2018-1.
11. Dai Clegg and Richard Barker. 1994. *Case method fast-track: a RAD approach*. Addison-Wedley Longman Publishing Co., Inc.
12. Hae Won Park, Rinat Rosenberg-Kima, Maor Rosenberg, Goren Gordon, and Cynthia Breazeal. 2017. *Growing Growth Mindset with a Social Robot Peers*. 2017 ACM/IEEE International Conference on Human-Robot Interaction (HRI '17) from <https://dam-prod.media.mit.edu/x/2017/03/30/parl2017hri-mindset.pdf>
13. Abigail Sellen, Yvonne Rogers, Richard Harper, and Tom Rodden. 2009. *Reflecting Human Values in the Digital Age*. *Communications of the ACM*. 52. 10.1145/1467247.1467265.
14. Eyssel, Friederike, and Frank Hegel. 2012. "(S)He's Got the Look: Gender Stereotyping of Robots1." *Journal of Applied Social Psychology*, vol. 42, no.9, 2012, pp. 2213-2230., doi:10.1111/j.1559-1816.2012.00937.x.
15. Eyssel, Friederike, and Dieta Kuchenbrandt. 2011. "Social Categorization of Social Robots: Anthropomorphism as a Function of Robot Group Membership." *British Journal of Social Psychology*, vol. 51, no. 4, 2011, pp. 724–731., doi:10.1111/j.2044-8309.2011.02082.x.
16. B.Tay, Y. Jung, and T.Park. 2014. "When Stereotypes Meet Robots: The Double-Edge Sword of Robot Gender and Personality in Human–Robot Interaction." *Computers in Human Behavior*, vol. 38, 2014, pp. 75–84., doi:10.1016/j.chb.2014.05.014
17. Jinjoo Lee. 2017. "A Bayesian Theory of Mind Approach to Nonverbal Communication for Human-Robot Interactions." PhD Thesis, Massachusetts Institute of Technology, 2017, www.media.mit.edu/publications/jinjoolee-phd-2017/.
18. James Auger. 2014. *Living with robots: a speculative design approach*. *J. Hum. -Robot Interact.* 3, 1 (February 2014), 20-42. DOI: <https://doi.org/10.5898/JHRI.3.1.Auger>